

# CHARGED AIR COOLERS

---

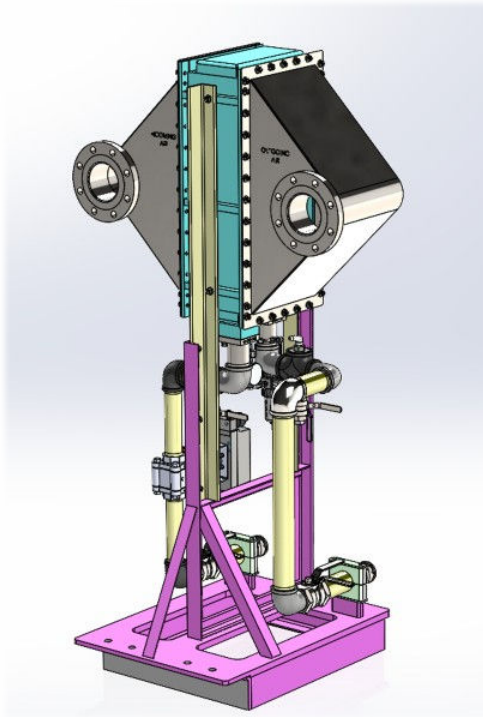

---

## OVERVIEW

Custom engineered and manufactured for fitment and function charged air coolers play a critical role for engine testing. Charged air coolers allow turbocharger air to be cooled using facility air before engine intake.

---

## KEY FEATURES

- Custom engineered for required fitment and usage
- Stationary mounted designs
- Integrated with data acquisition and controls
- Overhead crane positioned
- Flexible solutions tailored to required volume and temperature conditions
- Turn-key system delivery