

# FIXTURE CART

---

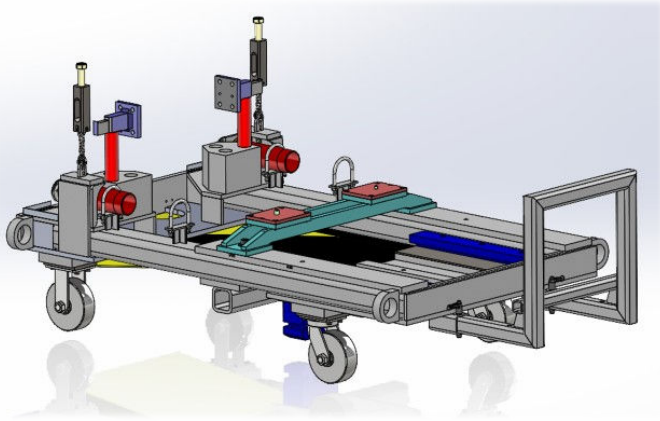

---

## OVERVIEW

Fixture carts are used to handle and precisely dock and align units under test. They also allow the ability to pre-rig and stage units under test requiring less test cell downtime. Test cycle efficiency is raised by allowing unit under test preparation outside of the test cell.

---

## KEY FEATURES

- Custom engineered to interface with unit under test
- Stress analyzed for proper load handling and rigidity
- Flexible solutions tailored to specific unit under test or universal customer adaptation
- Turn-key system delivery
- Easily install and prepare unit under test anywhere in facility
- Automate in cell driveline, fuel, air and water connections
- Easily handle units under test while on cart
- Pair with powered cart mover to increase handling load capacity
- Heavy duty alignment pins and bushings pair with docking system to precisely align unit under test centerline
- Precision machined surfaces paired with tooling maintain high tolerance unit under test centerline