

# HORIZONTAL VERTICAL TEST STAND

---

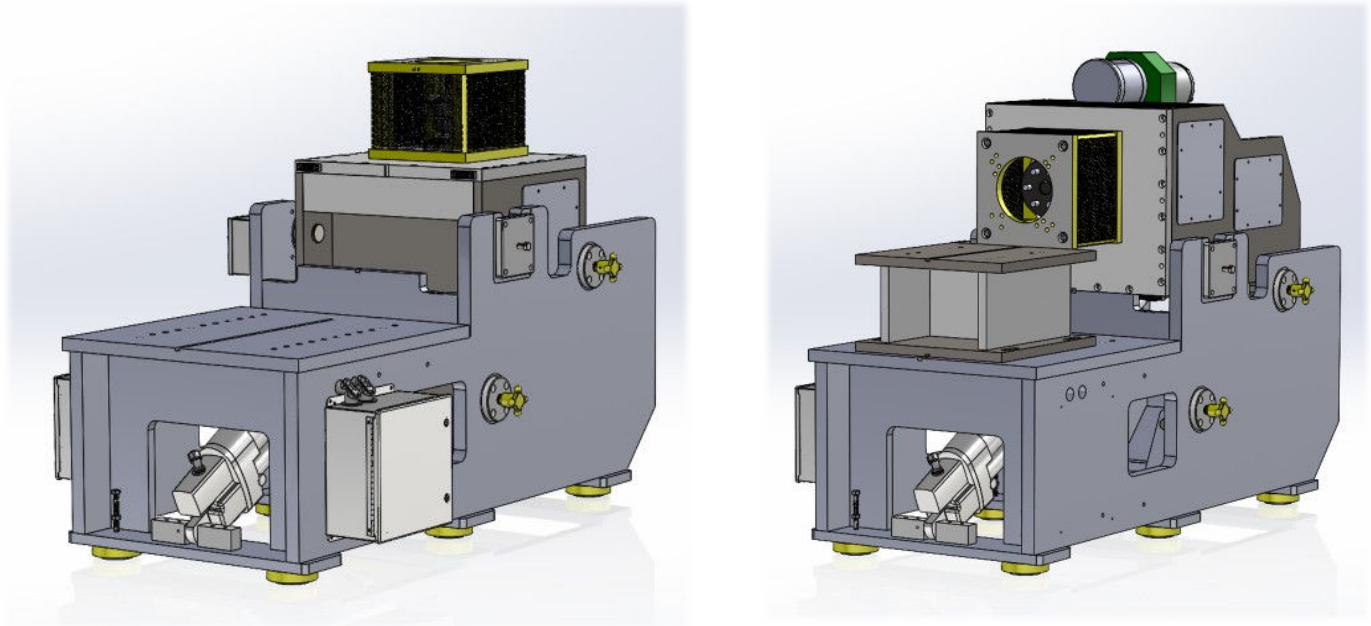

---

## OVERVIEW

This system combines multiple test setups into one highly flexible solution for small engine testing needs.

---

## KEY FEATURES

---

- Custom engineered for required needs and performance
- Analyzed for proper load handling and rigidity
- Flexible solutions tailored to specific customer requirements
- Flexible all-in-one solution
- Turn-key system delivery
- Accurate fixturing and coupling
- Stable and vibration resilient
- Flexible design offerings
- Horizontal + horizontal offset test
- Vertical + vertical offset test
- Increases range of test capabilities